

OEM Piezoresistive Pressure Sensor

Model: PT124G-3103 (Digital type)



Description

PT124G-3103 is the OEM digital piezoresistive pressure sensor with 316L stainless steel corrugated diaphragm and isolated oil-filling construction. The sensing package utilizes silicone oil to transfer pressure from the 316L stainless steel diaphragm to the sensing die. The pressure is transformed to analog electric signal. By customized integrated circuit for temperature compensation and non-linearity correction, it outputs pressure data and temperature data conforming to I²C, SPI、MODBUS 485 interface protocol. It is widely used for various liquid pressure measurements which is compatible with stainless steel and Viton.

Features

Gauge, absolute, sealed gauge
Standard male thread for option
Isolated construction, enable to measure various liquid



Specifications

Item	Parameter
Range	-0.1MPa...0kPa~10kPa...3.5MPa
Pressure Type	Gauge, Absolute, Sealed Gauge
Over Pressure	1.5FS
Output	Digital I ² C, SPI、MODBUS 485 optional
Accuracy	±0.5%FS (pressure), ±1.5°C (Temperature)
Power Supply	(5±0.1)V DC; (3.3±0.1)V DC
Long Term Stability	±0.3%FS/year
Working Temperature	-10°C~80°C
Storage Temperature	-40°C~125°C
Shock	10g,20Hz~2000Hz
Impact	100g,11ms

Dimensions

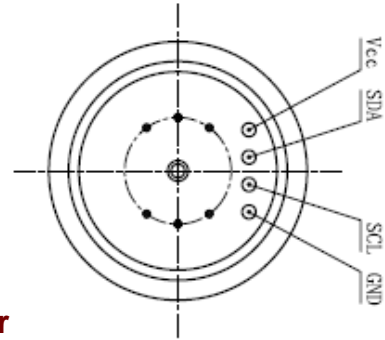
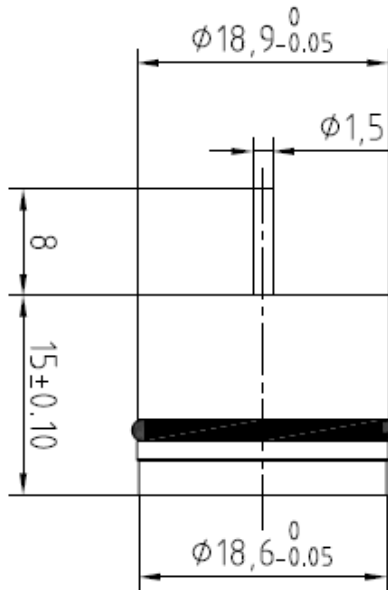

Wire lead color

PIN	Electric Connection	Wire lead color
1	V+	Red
2	V-	Yellow
3	S+	Blue
4	S-	White

Ordering guide

PT124G-3103 Digital Output Pressure Sensor			
	Range	-0.1MPa...0kPa~10kPa...3.5MPa	
	[0~X]kPa or MPa	X: actual measured range	
	Code	Power Supply	
	3	(3.3±0.1)VDC	
	5	(5±0.1)VDC	
	Code	Output Signal	
	A	10%~90% (1638~14746)	
	B	5%~95% (819-15563)	
	Code	Pressure Type	
	G	Gauge	
	A	Absolute	
	S	Sealed Gauge	
For example: PT124G-3103 (0~300]kPa 3BA			

Order Note:

1. Please pay attention that the measured media shall be compatible with contacted parts.
2. If zero pressure is negative, please make special note of exact pressure range in purchase order.
3. For special requirements, please contact us and make note in purchase order.

Shanghai Zhaohui Pressure Apparatus Co., Ltd

5-6F No.8 Building No.115 ,Lane 1276 Nanle Road
 Songjiang District Shanghai 201600 China
 Tel:+86-21-51691919 67755189 Fax:+86-21-67755185
 E-mail: info@zhyqsensor.com
 www.zhyqsensor.com

